

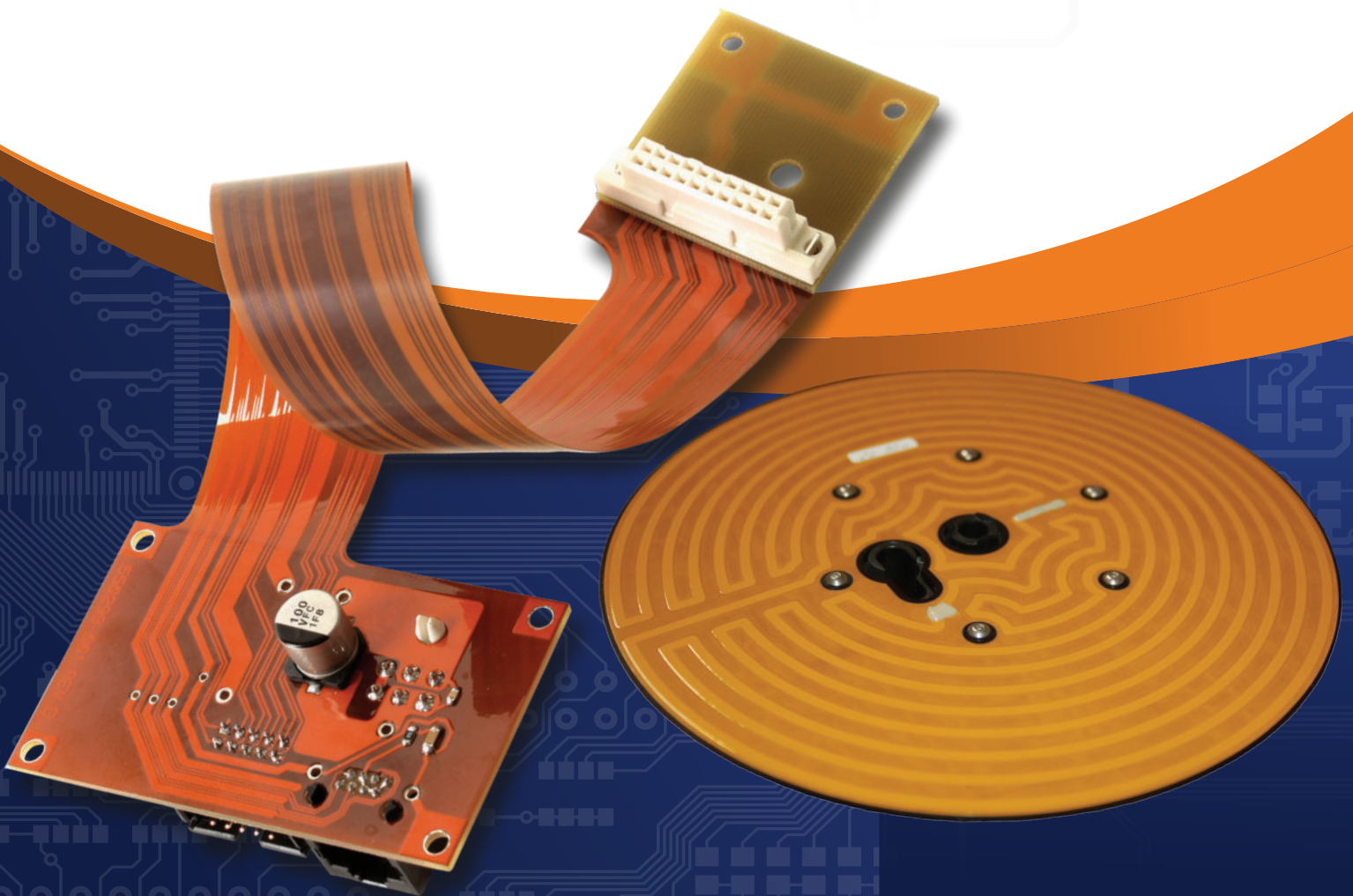

FLEXIBLE CIRCUIT AND HEATER DESIGN GUIDE



DOWNLOAD FROM OUR WEBISTE:

AllFlexInc.com



FLEXIBLE CIRCUIT AND HEATER DESIGN GUIDE

TABLE OF CONTENTS

BENEFITS OF FLEXIBLE CIRCUITRY	2
Benefits, Advantages, and Features	
ALL FLEX'S STANDARD CAPABILITIES	3 - 4
Design Considerations and Manufacturing Capabilities Standard Materials	
SINGLE-SIDED AND DOUBLE-SIDED CIRCUIT CONSTRUCTION	5
Cross Sectional View, Features When to Use Single-Sided and Double-Sided Flex	
MULTI-LAYER AND RIGID FLEX CIRCUIT CONSTRUCTION	6
When to Use Multi-Layer and Rigid-Flex	
MAXI-FLEX®	7
Features of these exceptionally long circuits 40'+	
FLEXIBLE HEATER CIRCUITS	8-11
Flexible Heater and Hybrid Heaters	
ADDED VALUE CAPABILITIES	12
Automated Pick and Place, Circuit Testing and Potted Circuits	
SURFACE DIELECTRICS OPTIONS	13
Coverlays Liquid Photoimageable Soldermask	
DESIGN GUIDELINES	14-15
Conductor Pad Design- Fillets, Tie-Downs, and Annular Rings Shaved and Elongated Pads, RADIUS Traces, and I-Beam	
SHIELDING	16-17
Solid Copper, Cross Hatched Copper Conductive Silver Conductive Shielding Film Stripline Impedance Chart	
RIGIDIZERS/STIFFENERS	18
FR4, Polyimide, and Polyester	
TERMINATION METHODS	19
ZIF End and Surface Mount All Flex Fingers	
ADDITIONAL TECHNICAL INFORMATION	20-22
Typical Properties of Dielectric Materials Current Carrying Capabilities and Current Rating Nomograph IPC Specification List	
COMPUTER AIDED DESIGN (CAD) INFORMATION	23
Design/Data Transfer Information	
GLOSSARY	24-25
REQUEST FOR QUOTE WORKSHEET	26

BENEFITS OF FLEXIBLE CIRCUITRY

1. A SOLUTION TO A PACKAGING PROBLEM.

- Flexible circuits allow unique designs which solve interconnection problems.
- The ability to fold and form flex circuits enables a package size reduction.
- Flex circuits make installation and repair practical and cost effective.

2. REDUCE ASSEMBLY COSTS

- Flex circuits can be tested prior to assembly of components.
- Reduction of connectors and solder joints lowers costs, and improve product reliability.

3. REPLACEMENT FOR A CIRCUIT BOARD AND WIRES.

- Flexible circuits simplify system design.
- Flex reduces the number of levels of interconnection required in an electronic package.
- Flexible circuits eliminate human error common in wire assemblies as routing is determined by artwork and repeatability is guaranteed.

4. REDUCE WEIGHT AND SPACE

- Considerable weight reduction is a benefit over wire harnesses, and rigid assemblies.
- Thickness can be as thin as .004 inches (.10mm) in total.

5. DYNAMIC FLEXING.

- The thinness of the material makes flexible circuitry the best candidate for dynamic flexing applications up to millions of flexures.

6. THERMAL MANAGEMENT/HIGH TEMPERATURE APPLICATIONS.

- Flex circuits dissipate heat at a better rate than any other dielectric materials.

7. AESTHETICS.

- Flex circuits improve the internal appearance of an electronic package, which can have an influence on the decision making process of prospective users of the product.

Quotes Provided In 24 Hours

- **E-mail: rfq@allflexinc.com**
- **www.allflexinc.com**
- **www.allflexheaters.com**
- **Secure FTP**
- **Call: 866-766-1334**

DESIGN CONSIDERATIONS FOR STANDARD MANUFACTURING CAPABILITIES

CIRCUIT CONSTRUCTIONS:

SINGLE-SIDED

DOUBLE-SIDED

MULTI-LAYER

RIGID FLEX

SHIELDING:

COPPER

TATSUTA, SILVER

STANDARD CIRCUIT SIZES:

(Longer available, considered MAXI-Flex®, see page 7)

SINGLE-SIDED: *(see page 5)*

up to 22" by 28"
(558.8mm by 711.2mm)

DOUBLE-SIDED: *(see page 5)*

up to 16" by 22"
(406.4mm by 588.8mm)

MAXI-FLEX®: *(see page 7)*

up to 20" by 40' plus
(508mm by Length)

MULTI-LAYER: *(see page 6)*

12" by 24"
(304.8mm by 609.6mm)

RIGID FLEX: *(see page 6)*

6-8 Layers standard construction
(depending on complexity
and design)

HOLE SIZE:

NON-PLATED

(Standard Processing)

THRU HOLES:

.005" (.125mm) min. drilled
hole size.
Tolerance +/- .0015" (.038mm)

PLATED THRU HOLE:

.005" (.125mm) min. drilled
hole size.
Tolerance +.003" (.076mm),
-.005" (.125mm)

(Smaller holes can be
manufactured, contact
All Flex Sales)

LINE WIDTH AND SPACING:

.004" (.1mm) MINIMUM LINE
.004" (.1mm) MINIMUM SPACING
(Finer lines can be manufactured,
contact All Flex Sales.)

CIRCUIT/BLANKING CONSIDERATIONS:

SOFT TOOLING:

Outline dimensions
+/- .005" (.125mm)
Radius of inside corners minimum
of .023" (.584mm)
Edge insulation
.010" min (.254mm)

HARD TOOLING:

Outline dimensions
+/- .001" (.0254mm)
Edge insulation
.006" min (.152mm)

LASER CUT:

Outline dimensions
+/- .003" (.25mm)
Edge insulation
.004" (.102mm)

DRILL POSITION:

Tolerance of +/- .003" (.076mm)

ZIF END TOLERANCE:

+/- .002" (.0508mm) with CpK>2.0

ADDED VALUE CAPABILITIES

**AUTOMATED MIXED FORM
FACTOR ASSEMBLY**

**SURFACE MOUNT
COMPONENTS**

Down to 0201
Thru hole assembly
(see more on page 12)

**PLACEMENT ACCURACY TO
.001"**

ROHS COMPLIANT ASSEMBLY

PRECISION STENCILING

HEAT SINKS

ELECTRICAL TESTING

FOLDING FORMING

**ALL FLEX CIRCUIT DESIGN
AND ENGINEERING WILL BE
HAPPY TO ASSIST YOU...**

STANDARD MATERIALS

BASE MATERIALS:

POLYIMIDE:

.0005" to .005"
(.012mm - .127mm)

POLYESTER:

.002" to .010"
(.050mm - .254mm)

ADHESIVELESS MATERIALS:

Copper thickness
.5 oz. to 4 oz.

FLAME RETARDANT:

Laminates and Coverlay

OTHER MATERIALS UPON REQUEST

BASE COPPER:

.5 oz. - .0007" (.018mm) thick
copper

1 oz. - .0014" (.036mm) thick copper
2 oz. - .0028" (.071mm) thick copper
3 oz. - .0042" (.107mm) thick copper
4 oz. - .0056" (.142mm) thick copper
5 oz. - .0070" (.178mm) thick copper
6 oz. - .0084" (.213mm) thick copper
7 oz. - .0098" (.249mm) thick copper

Thicker coppers are available
(call for information). See current
carrying chart on page 22.

SOLDER MASK:

POLYIMIDE COVERLAY:

.0005" to .005"
(.012mm - .127mm)

POLYESTER COVERLAY:

.0015" to .003"
(.038mm - .076mm)

PHOTO-IMAGEABLE COVERCOAT:

LPI - Liquid Photo Imagable -
for high density applications.

SURFACE FINISH:

HOT AIR SOLDER LEVEL (HASL)

RoHS Compliant and Tin Lead

TIN PLATING (ROHS COMPLIANT)

Electroless and electrolytic

SILVER (ROHS COMPLIANT)

Immersion

HARD GOLD OVER NICKEL (ROHS COMPLIANT)

(Typically used for contacts)

SOFT GOLD OVER NICKEL (ROHS COMPLIANT)

(Electrolytic - sometimes used
for bonding gold wire to the
gold layer)

ENIG (ELECTROLESS NICKEL IMMERSION GOLD) (ROHS COMPLIANT)

(Electroless - sometimes used for
bonding aluminum wire to the
nickel under the gold)

ORGANIC COATING

OSP (RoHS Compliant)

RIGIDIZERS/STIFFENERS:

FR4

drilled, routed, or scored

ALUMINUM

POLYIMIDE

POLYESTER

STAINLESS STEEL

CERTIFICATIONS:

ISO 9001: 2008 CERTIFIED

AS9100C

MIL-P-50884E QUALIFIED

ROHS COMPLIANT

IPC MEMBER:

Product is manufactured in
accordance with the requirements
of IPC-6013B Classes 1, 2, 3

ITAR REGISTERED

JCP CERTIFIED

UL RECOGNIZED:

for single and double sided
constructions with individual
polyimide layers up to 5 mil,
including several surface finishes.
(File # E161240)

Quotes Provided In 24 Hours

- E-mail: rfq@allflexinc.com
- www.allflexinc.com
- www.allflexheaters.com
- Secure FTP
- Call: 866-766-1334

SINGLE-SIDED AND DOUBLE-SIDED CIRCUIT CONSTRUCTION

SINGLE-SIDED FLEXIBLE CIRCUITS

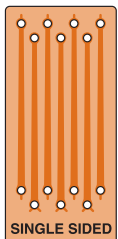

Single-sided flexible circuits consist of a single conductive layer on a flexible dielectric film (see diagram below).

SINGLE-SIDED FEATURES:

- Very thin construction .004”-.008” (.10mm - .20mm)
- 1 Conductive layer.
- Reverse bared or back bared pads, provide access from both sides of the part.
- Supported and unsupported finger areas.

WHEN TO USE SINGLE-SIDED FLEX:

- Dynamic flexing applications
- Unusual folding and forming applications.
- Installation/service applications/repair.
- Limitations on space / thickness
- Installation / Service flexing

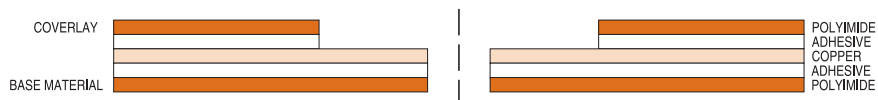

(refer to standard materials page for material availability)

A UNIQUE TYPE OF SINGLE-SIDED CIRCUIT SCULPTURED FLEX CIRCUITS

Sculptured flex circuits have variable copper thicknesses within the part. Thin copper is used for the flexible regions, and thicker copper is used at the interconnection point. Sculptured flex circuits provide bare metal connections and are a highly reliable alternative to mechanically crimped contact pins.

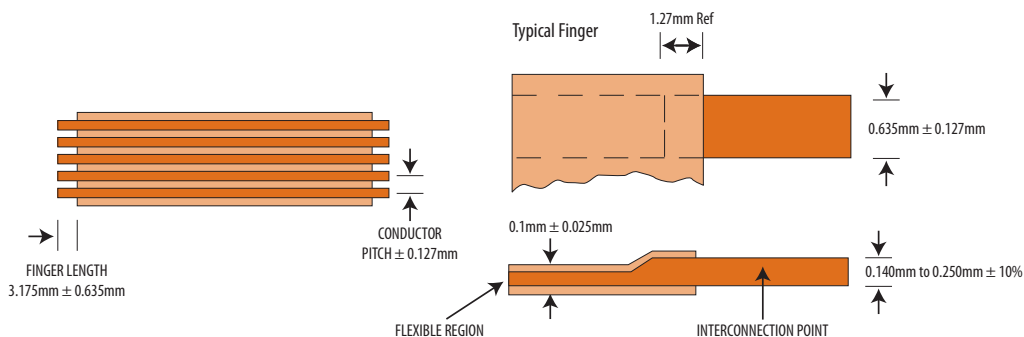

DOUBLE-SIDED FLEXIBLE CIRCUITS

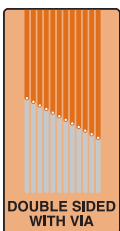

Double-sided flexible circuits consist of two conductive layers normally connected with a plated through-hole (see diagram below).

DOUBLE-SIDED FEATURES:

- Component assembly available on both sides.
- Two conductive layers.

WHEN TO USE DOUBLE-SIDED FLEX:

- Required when circuit density and layout cannot be routed on a single layer.
- Ground and power plane applications.
- Used for shielding applications.
- Dense surface mount assembly.

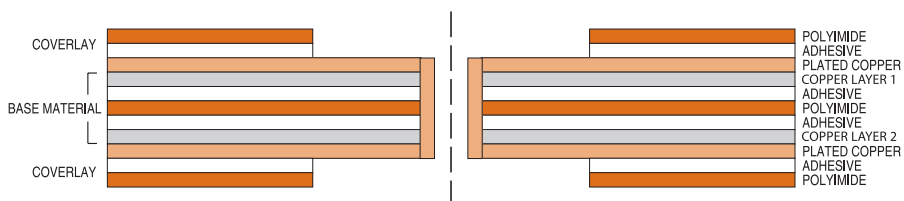



(refer to standard materials page for material availability)

MULTI-LAYER AND RIGID-FLEX CIRCUIT CONSTRUCTION

MULTI-LAYER CONSTRUCTION CIRCUITS

Controlled impedance and shielding possible.

-  COPPER
-  PI (Polyimide)
-  ADHESIVE ADDED BETWEEN EACH

WHEN TO USE MULTI-LAYER FLEX:

- Required when circuit density and layout can not be routed on a single or double layer.
- Ground and power plane applications.
- Used for shielding applications.
- Dense surface mount assembly.
- Increased circuit density.
- EMI/RFI shielding.
- Controlled impedance with shielding.

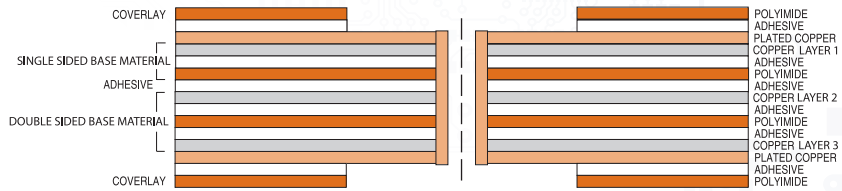

(refer to standard materials page for material availability)

RIGID-FLEX CIRCUITS

Rigid-Flex circuits are characterized by having conductors on both the flexible and rigid layers of the circuit. Plated thru holes extend between the flexible and rigid sections and electrically connect multiple conductor layers. Rigid-flex circuits are often used when components are mounted on both sides of the rigid section. This circuit construction is known as a Type 4 circuit as defined by IPC 6013 and should be distinguished from a flexible circuit with a rigid stiffener attached.

(inquire within)

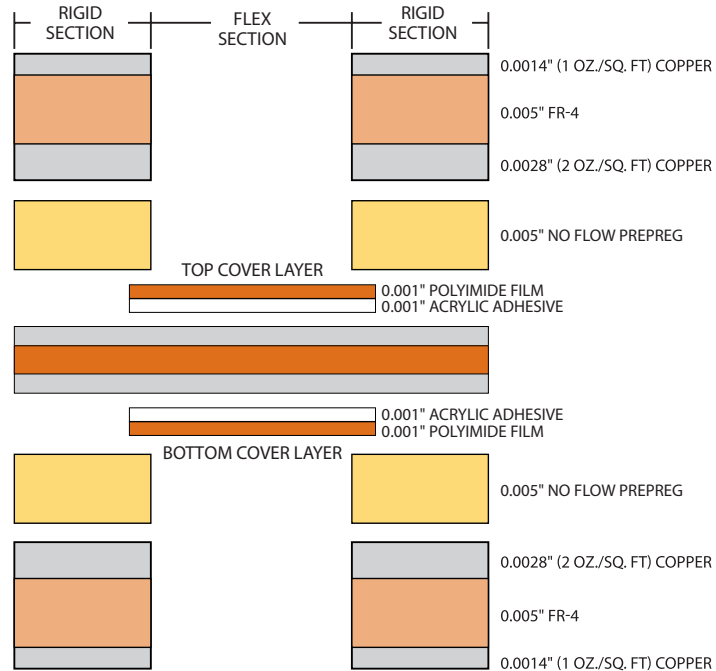

Quotes Provided In 24 Hours

- E-mail: rfq@allflexinc.com
- www.allflexinc.com
- www.allflexheaters.com
- Secure FTP
- Call: 866-766-1334

MAXI-FLEX®

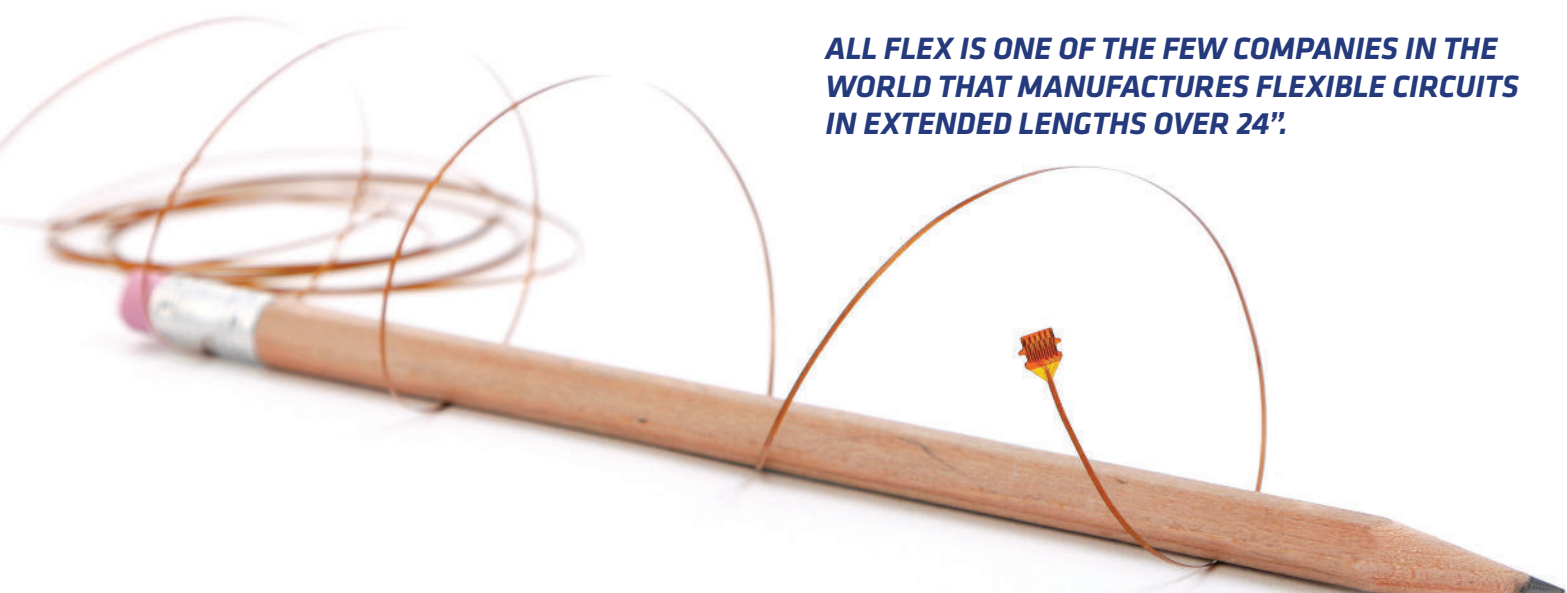

ALL FLEX IS ONE OF THE FEW COMPANIES IN THE WORLD THAT MANUFACTURES FLEXIBLE CIRCUITS IN EXTENDED LENGTHS OVER 24”.

MAXI-FLEX®

All Flex has trademarked our special flex circuit offering that allows an application to be produced at larger than normal sizes. Maxi-flex® is a circuit that is typically found on one or two conductive layers longer than 24” in length. Additional layers may be added.

Custom Designed Copper Flexible Circuits in exceptionally long lengths up to 40’+.

- Sizes from 2’ to 40’+ by 20” max
- Single-sided, double-sided, multi-layer
- Plated through holes
- Ideal for large systems and unmanned systems
- Permits tight bends
- Eliminates bulky cabling
- For use in military and aerospace applications
- Standard conductor pitch down to 0.030” (0.76mm) (finer pitch available, call ALL FLEX sales for more information)
- Shielding possible to provide EMI/RFI protection
- Controlled impedance design available
- Light Weight, dense packaging solutions

- Replacement for wire harnesses
- Custom termination design for use with:

High density circular connectors

D subminiature connectors

Surface mount connectors and components

Pin and socket connectors

Leaded components

Edge card and zif connectors

Crimp-on/displacement pins and connectors

MAXI-FLEX® circuits can be designed for specific applications with signal, power and shielding layers in one complete interconnect package.

(IMPORTANT: DUE TO MATERIAL AVAILABILITY in these lengths, contact All Flex staff for further information on standard MAXI-FLEX® construction options.)

CUSTOM HEATERS - FEATURES/ADDED VALUE

ALL FLEX HAS THE UNIQUE CAPABILITY TO MANUFACTURE HEATERS AND ASSEMBLE COMPONENTS

All Flex can design, fabricate, and reverse engineer flexible heaters to meet customer's exact requirements. Flexible polyimide and silicone rubber heaters and heater component assemblies are fabricated with a variety of resistive metal alloys to deliver custom solutions for heating capacity, watt density, and other application specific customer needs. Typical lead times 2 – 3 weeks.

FLEXIBLE HEATER FEATURES:

- Temperatures up to:
200°C Polyimide
232°C Silicone Rubber
- Circuit size up to 22" x 30"
(558mm x 762mm)
- Resistant to most chemicals
- Engineered to meet specified output
- Flexible Heaters can be supplied as thin as .004"
- Component and connector assembly
- Soldered wire assembly for connections
- Epoxy reinforced soldered wires
- Bifilar Heater - A heater that consists of two parallel traces of differing resistance. User can heat one, the other, or both traces essentially making three heaters in one. Bifilar heaters can be advantageous if the user wants to keep control logic to a minimum.

OTHER CONSIDERATIONS / ADD ONS:

- Thermistor assembly
- Heater can be built with multiple heating zones
- Quick turn available
- Any volume quantities
- Assembly expertise
- Epoxy coated solder joints provide strain relief and insulation and environmental protection
- UL Recognized
(File #E338387)
(Category KSOT2)
- PSA – Pressure Sensitive Adhesive can be applied to either surface for a peel and stick application

- Heat spreaders of aluminum can be applied to the heater to reduce the incidence of hot spots
- Designs can be manufactured to reduce or eliminate heat in certain positions of the heater
- Heaters can be designed/ manufactured into virtually any size or shape, with or without clearance holes
- All heaters are custom designed and manufactured to customer specifications
- Special marking of part number or image

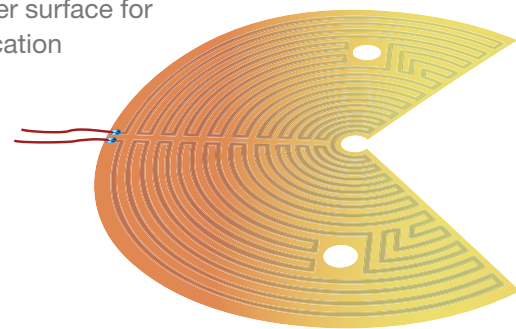

Heaters can be designed and manufactured into virtually any size and shape. Parts can be supplied with pressure sensitive adhesive for easy attachment to heat sinks.

ALL FLEX SUPPORT CAN REVERSE ENGINEER TO MEET EXACT REQUIREMENTS

Quotes Provided In 24 Hours

- E-mail: rfq@allflexinc.com
- www.allflexinc.com
- www.allflexheaters.com
- Secure FTP
- Call: 866-766-1334

CUSTOM HEATERS

POLYIMIDE AND SILICONE RUBBER HYBRID

All Flex engineering will work closely with you to ensure the proper design and layout. The following are typical characteristics and parameters of our heater circuit products.

DESIGN PARAMETERS

Characteristics	Typical Parameters – Polyimide	Typical Parameters – Silicone
	<i>* Note - these are standard parameters inquire within for requirements beyond this range</i>	
Size Range*	Less than 1/2" square up to 10"x22"	Less than 1/2" square up to 24"x30"
Temperature Range	Up to 392° F (200° C)	Up to 450° F (232° C)
Resistance Range	Up to 250 Ω per sq in	Up to 250 Ω per sq in
Metal Thickness Range*	.0005" - .002"	.0005" - .002"
Total Thickness Range*	.0045" - .01"	.03" - .06"
Dielectric Range/ Insulation Resistance	4000-5000 V/mil	400-600 V/mil
Example Power Densities	2.5 W/in ² -low end, 5 W/in ² -all purpose, 10 W/in ² -rapid warmup	2.5 W/in ² -low end, 5 W/in ² -all purpose, 10 W/in ² -rapid warmup
Resistance Tolerance*	+/- 10%	+/- 10%
Maximum Voltage	Up to 115 V	Up to 220 V
Standard Coverlay Thickness	.001", .002", .003" and .005"	.015"
Leads (if required)	Length/AWG/Coating	Length/AWG/Coating

Multi-zone heaters give customers full flexibility in managing their processes while offering uniform and easy to install elements. Available in both polyimide and silicone rubber.

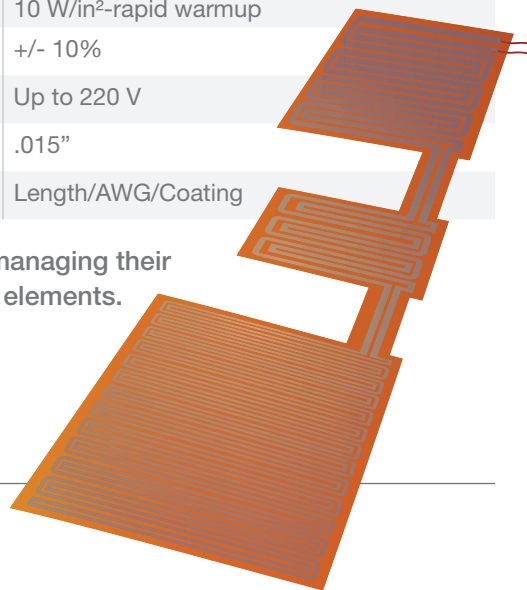

HYBRID HEATERS

Now your single or double sided circuit assembly can have built-in heaters. All Flex can take your electronic circuitry requirements and your heat requirements and create a hybrid product. Typically the heater function is on one side of the base film and the electronics function is on the opposite side. By combining a copper layer for the electronics with a layer of resistive metal for the heater, a hybrid circuit can be designed. Top to bottom electrical connection can be done with plated thru holes. All Flex has unique process and materials that can accommodate even the most challenging hybrid requirements.

ADVANTAGES OF A HYBRID HEATER:

- Thinner overall profile
- Reduces overall assembly weight
- More robust functionality
- Lower over all costs

HEATER APPLICATIONS

MEDICAL

All Flex heaters provide precise heating and thermal control in applications where thermal management is extremely important.

All Flex Understands:

- Medical quality requirements
- FDA traceability expectations
- Medical device qualification procedures
- Clean room/precision assembly needs of medical customers
- Medical device product development cycles
- Small and medium volume delivery needs

Some Applications:

- Incubator
- Operating room equipment
- Surgical tools
- Defibrillator
- Dialysis equipment
- Blood analysis equipment
- Medical instrumentation and laboratory equipment

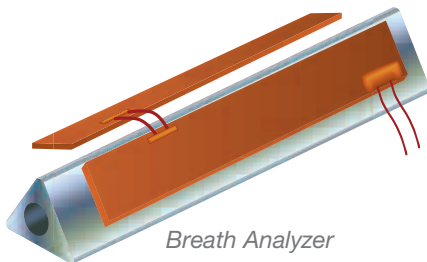

Breath Analyzer

AERONAUTICS/AEROSPACE

All Flex is AS9100, ISO 9001:2008 Certified, ITAR Registered, Mil-P-50884E Compliant.

Heating technology is used extensively in the Aeronautics and Aerospace industry due to the temperature extremes and the need for reduced weight and compact electronics.

All Flex heaters help to maintain high reliability of electrical components by limiting exposure to high degrees of thermal contraction/expansion cycles.

All Flex Heaters also keep non-electrical components at constant temperatures for both functional and convenience purposes.

The typical application for heaters in this industry is not to heat devices to high temperatures, but to keep devices from getting cold. Our technology enables us to fabricate heaters that remain flexible and compliant at -55 degrees C (-67 degrees F) while heating to slightly above freezing.

Some Applications:

- Helicopter controls
- Aircraft controls
- De-icing systems
- Satellite hardware
- Cockpit systems

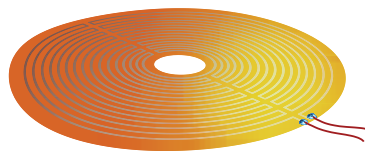

Lab Analysis Heater

MILITARY/DEFENSE

All Flex is AS9100, ISO 9001:2008 Certified, ITAR Registered, Mil-P-50884E Compliant.

All Flex Heaters provide an excellent solution for high performance, densely packed electronics where space is a premium yet heating of components are needed. Numerous All Flex Flexible Circuits are used by prime contractors, NASA, developmental laboratories, and government agencies.

Some Applications:

- Aircraft equipment
- Night vision
- Sighting systems
- Ruggedized computers

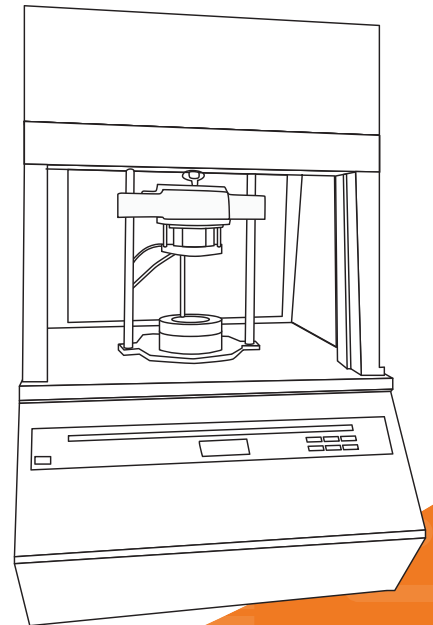

Quotes Provided In 24 Hours

- E-mail: rfq@allflexinc.com
- www.allflexinc.com
- www.allflexheaters.com
- Secure FTP
- Call: 866-766-1334

HEATER APPLICATIONS AND STOCK HEATERS

OUTDOOR ELECTRONICS

Devices and equipment that are exposed to cold temperatures creates design challenges for manufacturers. Typical thermal cycling introduces molecular expansion issues that can impact electronics, cause mechanical wear, introduce moisture variation, restrict moving parts, and other functional and operational problems.

Some Applications:

- Automated Teller Machines
- Outdoor LED and Canister Lighting
- Outdoor LCD Screen
- Ruggedized electronic and computer devices made to operate in extreme weather conditions

GENERAL & INDUSTRIAL ELECTRONICS

All Flex Heaters are used in a wide variety of electronic applications to assist in the performance of our customers' end products.

Some Applications:

- Food service equipment
- Storage tanks
- Battery heaters to enhance battery performance
- Photo processing
- Outdoor antenna
- Hand-held scanners

STOCK HEATERS

(for production products or test/evaluation)

Generally our customers have unique design requirements that necessitate customization for their particular device or application, however one of our standard heaters may meet your needs, All Flex offers standard, non-custom flexible heaters. These heaters are classified as either Stocked or Build to Order (BTO) and are available without a tooling or set-up charge.

Select size/shape, resistance, or watt density (watts per square inch) to determine if a particular stock product meets your needs then assess the additional options below that may be required.

Stocked heaters options:

- Each stocked heater is available with a pressure sensitive back-piece cut to the same size as the heater.
- Aluminum heat-dissipation shield, cut to the same size as the heater.
- Custom marking is available as specified and desired by the customer.
- The addition of wires and associated wire characteristics
- UL Recognition

Visit: WWW.ALLFLEXHEATERS.COM for a complete listing of all standard stock heaters, technical detail, lead times, pricing, option pricing, etc.

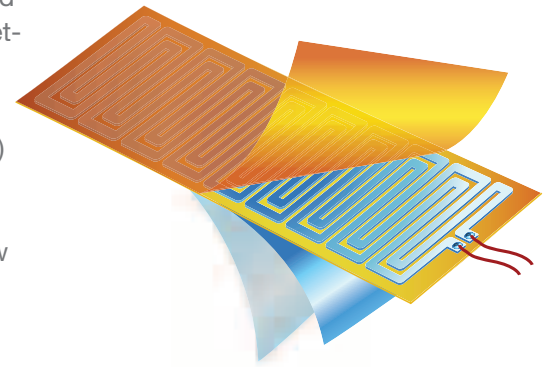

All Flex heaters can be supplied with PSA (Pressure Sensitive Adhesive) on the back of the heater with a release liner for easy peel and stick, the PSA makes installation quick and easy.

To order call:
877-663-7162

or email:
customersupport@allflexinc.com

**OUR VISION IS TO
BE YOUR PREFERRED
SUPPLIER FOR FLEX**

ALL FLEX ADDS VALUE

MAXI-FLEX®

All Flex has the capability to quickly design, manufacture and deliver in volumes from prototype to production. All Flex has manufactured hundreds of designs for the military, medical and industrial markets.



HAND ASSEMBLY

- Operators certified to J-STD
- Lead and lead free capability
- ESD controls

AUTOMATED PICK AND PLACE CAPABILITY PROVIDES COMPLEX ASSEMBLY COMBINATIONS INCLUDING :

- Surface mount components down to 0201
- Precise vision system allows placement accuracy to .001"
- Fine pitch capability to .5mm pitch
- Leaded devices
- Tactile domes
- Staked terminals
- Unlimited component configurations
- RoHS Compliant assembly
- Virtually all SMT components including discretes, SOICs, PLCCs, QPPs, & BGA's
- Auto fiducial correction



AUTOMATED ASSEMBLY

Solder Screener

- Automated screening of solder onto arrays/panels using solder stencil
- Lead and lead free capability

Selective Soldering

- Automated ability to solder leads on through hole connector
- Lead and lead free capability

OTHER ALL FLEX ADDED VALUE CAPABILITIES

- Thru hole assembly
- Flexible circuit folding and forming (see page 15)
- Electrical testing
- Heat Sinks
- Nomenclature Screening
- Stiffener placement
- Design and manufacturing support – concept to completion

CIRCUIT TESTING CAPABILITY

- Solderability
- Ionic contamination
- Dimensional tolerance
- Thermal testing
- Dielectric net-to-net
- Insulation resistance (IR)
- Microsections
- Continuity
- Inductance
- Capacitance
- Resistance
- Impedance

POTTED CIRCUITS

Connector securely adhered with potting compound to perform in rugged applications where vibration is typical



Quotes Provided In 24 Hours

- E-mail: rfq@allflexinc.com
- www.allflexinc.com
- www.allflexheaters.com
- Secure FTP
- Call: 866-766-1334

SURFACE DIELECTRICS OPTIONS

Surface dielectrics are applied to the outside layers of the circuit to insulate the copper conductors.

Following are types of surface dielectrics used at All Flex.

POLYIMIDE/POLYESTER COVERLAY

Coverlay is a polymer film coated with a thermoset adhesive. These materials are normally machined and shaped with a drilling process. Drilling limits the shapes available on coverlay features. Coverlay can be punched or blanked in lieu of the drilling process and is normally done for large coverlay openings.

VIA HOLE:

Plated thru hole generally covered with coverlay

COMPONENT HOLE:

.010" (.254mm) minimum larger than the copper pad

FEATURE DEFINITION:

.008" (.20mm) minimum

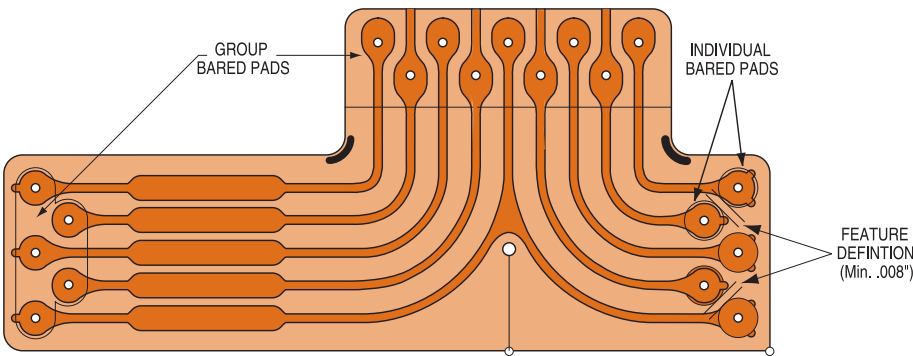

Note: Coverlay openings can be individual bared pads or group bared pads depending on area available.

Note: Group bared pads are used when there is not enough room to have individual openings.

LIQUID PHOTOIMAGEABLE SOLDERMASK

Liquid Photoimageable Soldermask (LPI) is produced by a photo lithography process and used to precisely locate the dielectric on the flex circuit features. This process enables unique openings to be applied anywhere on the circuit. LPI is usually not used with 2oz. copper or above due to the thickness of the copper as it may not conform around the area of some copper features.

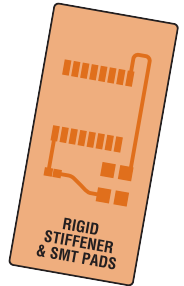

VIA HOLE:

Plated thru hole generally covered with soldermask

LPI Opening = .006" minimum larger than:

- pad with .004" minimum
- web spacing

SURFACE DIELECTRICS OPTIONS

Liquid Photoimageable Soldermask (LPI)	
ADVANTAGES	DISADVANTAGES
Higher pattern resolution	Not recommended for dynamic flex applications
Eliminates punching and drilling of access holes	Less robust mechanically
Polyimide /Polyester Coverlayer Films	
ADVANTAGES	DISADVANTAGES
Excellent dynamic flexibility	Adhesive may be susceptible to cleaning solvents
Pinhole free	Requires pre-cutting and/or pre-punching
Highest dielectric strength	Susceptible to misregistration/ dimensional change

DESIGN GUIDELINES: CONDUCTOR PAD DESIGN AND FILLETING

This section of our guide addresses rules specifically pertaining to conductor and pad design recommendations. Due to the flexible nature of the material during both manufacturing and application use, the following information is recommended to produce the highest yielding and best functioning flexible circuit. We call this “flexizing” the design. All Flex will flexize the conductor pattern on all part numbers to incorporate these reliability and manufacturability enhancements.

CONDUCTOR PAD DESIGN:

Pads should have tie-downs (also called anchoring spurs or rabbit ears). Tie-downs are captured by the coverlay to anchor the copper to prevent separation between the copper and the base material during assembly.

FILLETING:

All pads, on both through-hole and surface mount pads, should be filleted to reduce stress points. This helps eliminate breaking during flexing.

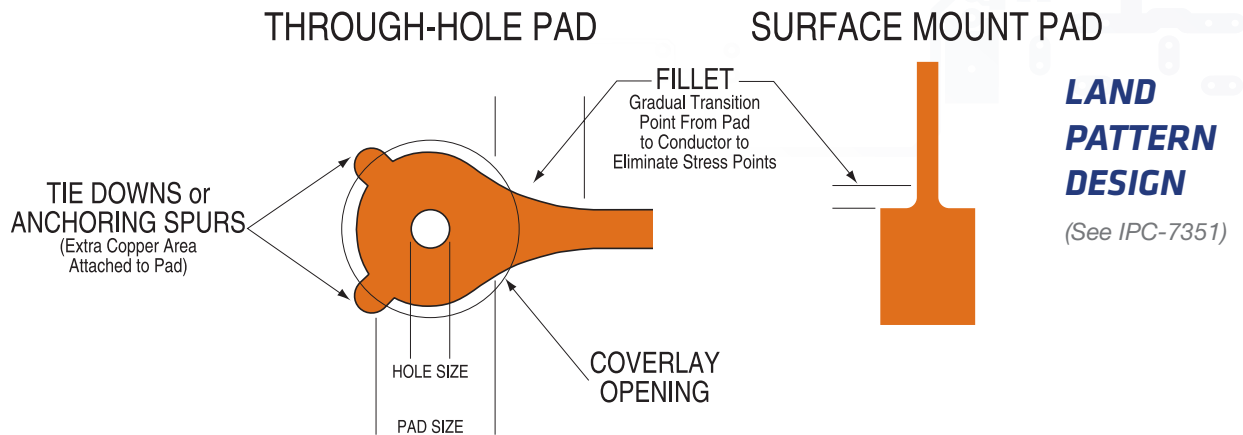

CALCULATING PAD SIZE:

Recommended pad size is dependent on the component pad requirement that is specific to your application.

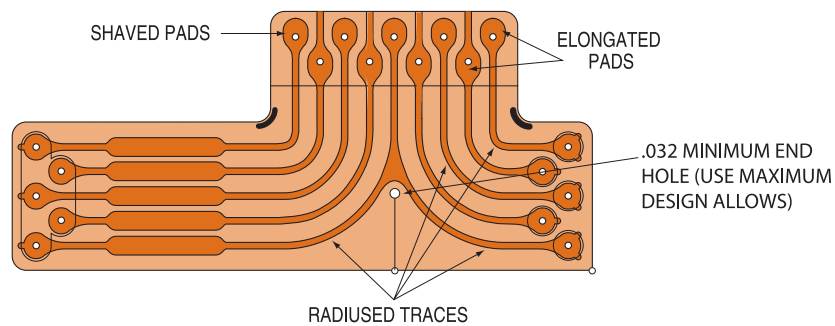

FORMULA:

$$\text{HOLE SIZE (FINISHED)} + \text{CUSTOMER REQUIRED TOLERANCES} + \text{ALL FLEX TOLERANCE} = \text{PAD SIZE REQUIRED}$$

.030" (.76mm)

±.003" (.07mm)

.020" (.50mm)

.053" (1.34mm)

Quotes Provided In 24 Hours

- E-mail: rfq@allflexinc.com
- www.allflexinc.com
- www.allflexheaters.com
- Secure FTP
- Call: 866-766-1334

DESIGN GUIDELINES: TO INCORPORATE IN BENDING AND FOLDING DESIGNS

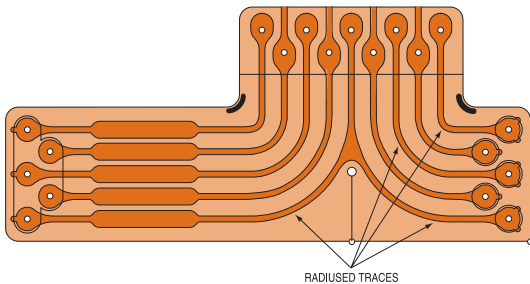

RADIUSED TRACES

Radiused Traces help to alleviate breaking during folding and bending.

I-BEAM

I-Beam constructions occur when the conductors on both layers lie directly on top of each other, increasing the stiffness of the circuit through fold areas. A better alternative is to stagger conductors, alternating their location to retain the maximum flexibility of the circuit.

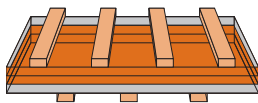

STAGGERED CONDUCTORS
Preferred Construction

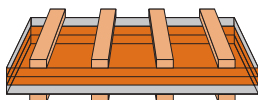

I-BEAM CONSTRUCTION
Not Recommended

FOLD LINES

Fold lines may be designated by "tick" marks which may be either in the copper layers or silkscreen layers. These features aid in bending and designating bend locations.

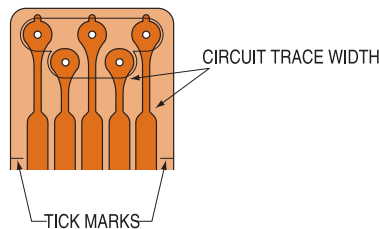

CIRCUIT TRACE WIDTH

Circuit trace width should not change in bend areas and the transition should be at least .030" (.76mm) from the fold line.

BEND RADIUS

Bend Radius of a flex should be approximately 10 times the material thickness and at least .050" away from the plated through hole.

$$r = 10 \times T$$

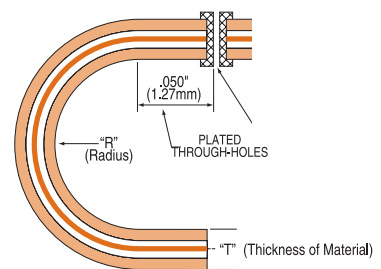

BUTTON PLATING / PADS ONLY PLATING

This is a process that allows for the plated through holes to maintain their connection while the traces are not plated, allowing the circuit to have increased flexibility.

SHIELDING

If your application requires limits in electromagnetic and/or electrostatic interference, shielding may be required. Shields are material around a conductor or group of conductors that limit these factors.

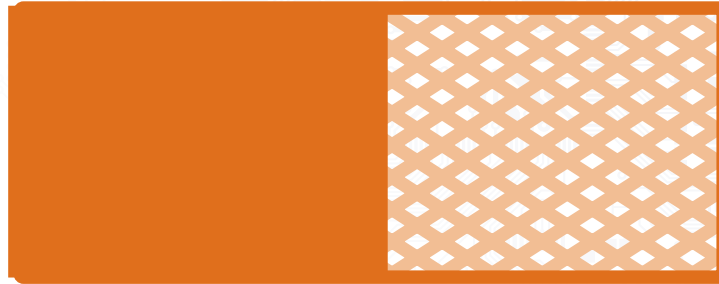

SOLID COPPER:

Solid Copper is the most common method of shielding. Solid copper shields increase the rigidity of the circuit, and should be included in thickness to bend radius ratios. Copper shield can be put on one or both sides of the circuit. Solid copper can also cover selective conductors.

CROSSHATCHED COPPER:

Crosshatching is an artwork design that relieves much of the copper shield areas by the use of a pattern. Crosshatching helps the circuit to retain its flexibility and can be put on one or both sides. Crosshatch shielding can also cover selective conductors.

Note: Additional shielding options exist, such as shielding between circuit conductor. Contact All Flex Staff for further details.

CONDUCTIVE SILVER:

Conductive silver can be substituted for the copper for shielding purposes in some applications. Silver shielding is not recommended for a dynamic flexing application due to its brittle characteristic, and may be prone to cracking in severe bending applications. Silver can be a solid or crosshatched shield and can be put on one or both sides of the circuit. It can also cover selected conductors only.

CONDUCTIVE SHIELDING FILM:

Metalized film with a conductive adhesive coating is thermally bonded to flexible circuitry. Selective openings in the coverlay film allow the conductive adhesive to electrically contact the flex circuit. This creates a shielding layer by the contact between the metalized film and the ground traces.

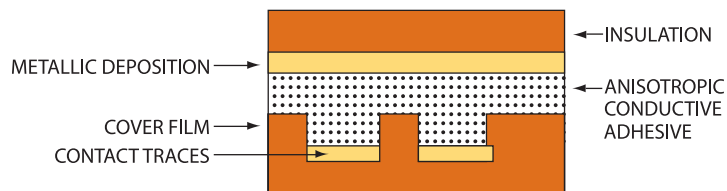

Quotes Provided In 24 Hours

- E-mail: rfq@allflexinc.com
- www.allflexinc.com
- www.allflexheaters.com
- Secure FTP
- Call: 866-766-1334

SHIELDING

CHARACTERISTIC IMPEDANCE:

Controlled impedance is important in high speed digital circuitry to avoid signal reflectance and power loss. The impedance of a flexible printed circuit depends on dielectric constant of the base material, conductor width, conductor thickness and dielectric thickness.

STRIPLINE

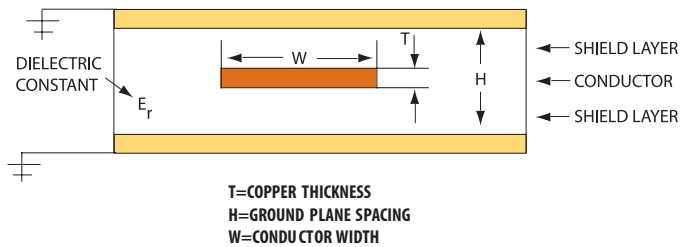

SINGLE ENDED MICROSTRIP

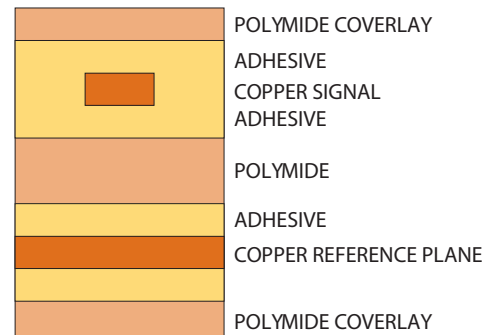

FLEXIBLE POLYIMIDE CIRCUIT - IMPEDANCE REFERENCE CHART

Single Ended Microstrip				
MATERIAL THICKNESS INCLUDING ADHESIVE	TRACE WIDTH FOR 50 OHMS IMPEDANCE 1/2 OZ COPPER	TRACE WIDTH FOR 50 OHMS IMPEDANCE 1 OZ COPPER	TRACE WIDTH FOR 75 OHMS IMPEDANCE 1/2 OZ COPPER	TRACE WIDTH FOR 75 OHMS IMPEDANCE 1 OZ COPPER
0.002	0.0036	0.0032	0.0015	>.001
0.003	0.0057	0.0053	0.0025	0.0013
0.004	0.0078	0.0074	0.0035	0.0028
0.005	0.0102	0.0096	0.0050	0.0041
0.006	0.0122	0.0117	0.0060	0.0050
0.007	0.0144	0.0139	0.0070	0.0060
0.008	0.0166	0.0161	0.0080	0.0068
0.009	0.0189	0.0184	0.0088	0.0085
0.010	0.0211	0.0206	0.0105	0.0095

All calculations assume .002 thick coverlay, 3.4 dielectric constant and 50% trace/ 50% space on differential pairs

RIGIDIZERS/STIFFENERS

Often circuit applications require support in areas where connectors or other components are applied. Here are the recommended types of guidelines for stiffeners.

FR4/G10 STIFFENERS:

- Come in a variety of thicknesses such as .010" (.25mm), .020" (.50mm), .031" (.78mm), .047" (1.19mm) and .062" (1.57mm).
- Can be bonded to a flex circuit using a pressure sensitive adhesive or a thermoset adhesive.
- Are normally used to give added rigidity under a component area.
- Used as a carrier panel for automated assembly processing.
- Hole size in the stiffener should be .015" (.38mm) larger than the circuit thru-hole to allow for registration tolerances.

POLYIMIDE OR POLYESTER STIFFENERS:

- Come in a variety of thicknesses from .001" (.02mm) up to .015" (.38mm) or higher.
- Can be bonded to a flex circuit using a pressure sensitive adhesive or a thermal set adhesive.
- Can be used to give added thickness under conductors to meet ZIF connector requirements.
- Can be used to give added strength in high wear areas.
- Can be blanked at the same time as the circuit outline to meet tight tolerance requirements.

LOCATION OF STIFFENER:

Stiffener and coverlay termination points should overlap a minimum of .030" (.76mm) to avoid stress points. Eliminating stress points reduce the chance of traces breaking.

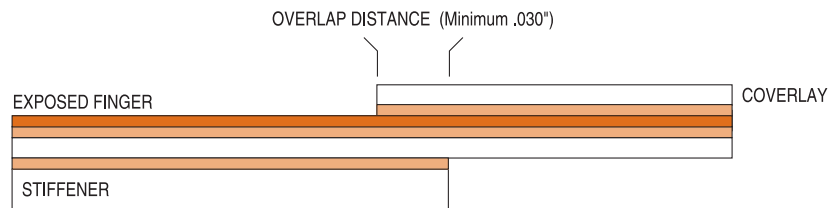

(This is the **PREFERRED METHOD** because there is not common ending point of the coverlay and stiffener.)

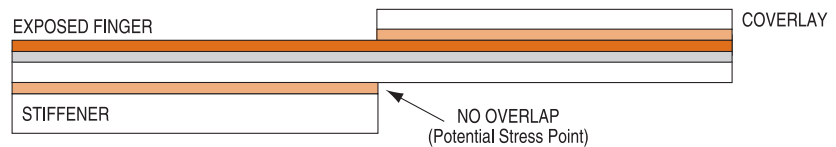

(This form is **NOT RECOMMENDED** because it allows potential stress and cracking points where the coverlay and stiffener end at a common edge.)

Quotes Provided In 24 Hours

- E-mail: rfq@allflexinc.com
- www.allflexinc.com
- www.allflexheaters.com
- Secure FTP
- Call: 866-766-1334

TERMINATION METHODS

There are many ways to terminate a flexible circuit. Following are common methods for consideration.

ZIF CONNECTORS:

Zero Insertion Force connectors are a popular method to terminate a flexible circuit. ZIF connector fingers on the flex circuit insert into a mating connector. The ZIF end inserted into the connector are usually located on a rigid board.

Blank tolerance +/- .002"



THRU-HOLE OR SURFACE MOUNT CONNECTORS:

These are the traditionally used connectors in today's circuit boards.

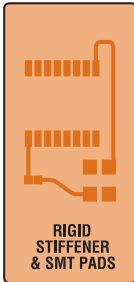
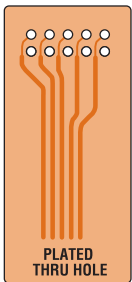

CRIMPED CONTACTS AND DISPLACEMENT CONNECTORS:

- Contacts crimp through the dielectric material into the copper conductor.
- Contacts are available for .100" (2.54mm) or .050" (1.27mm) centers.
- Centerline housings are also available to encapsulate the contact.

SCULPTURED (UNSUPPORTED) TRACES AND POWER FLEX:

- Thicker copper allows flexible circuit designs to carry higher current through small spaces.
- Selective etching allows a reduction in copper thickness in selective areas for increased flexibility.
- Copper thickness from 0.003" (0.076mm) to 0.010" (0.254mm)

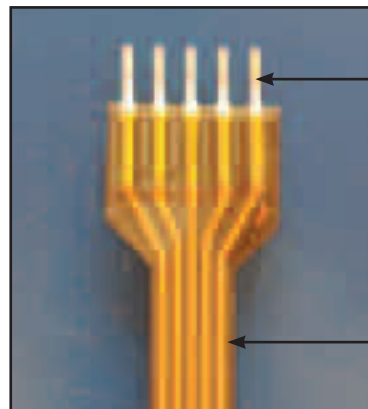

Sculptured (unsupported) Traces

ADDITIONAL CUSTOM TERMINATION OPTIONS:

- High density circular connectors
- D subminiature connectors
- Pin and socket connectors
- Leaded components

RECOMMENDED SUPPLIERS LIST FOR FLEXIBLE CIRCUIT CONNECTORS:

1. Digi-Key (800) 344-4539
www.digikey.com
2. NAC Semi (866) 651-2901
www.nacsemi.com
3. Samtec (800) 726-8329
www.Samtec.com
4. TTI (800) 225-5884
www.TTIInc.com

**REQUEST QUOTES, SAMPLES,
AND DESIGN CONSULTS ONLINE
AT ALLFLEXINC.COM**

ADDITIONAL TECHNICAL INFORMATION

IPC INFORMATION

The following list contains the IPC specifications that you can reference in regards to specific materials, design, performance and assembly questions.

MATERIALS

IPC-4202

Flexible Base Dielectrics

IPC-4203

Adhesive Coated Dielectric Films

IPC-4204

Flexible Metal-Clad Dielectrics

IPC-4101

Rigid PC Board Materials

DESIGN

IPC-FC-2221

Generic Standard on Printed Circuit board Design

IPC-FC-2222

Rigid Circuit Boards

IPC-FC-2223

Flexible Circuits

PERFORMANCE

IPC-6011

Generic Performance Specifications for Printed Circuits

IPC-6012

Qualification and Performance for Rigid Circuit Boards

IPC-6013

Qualification and Performance for Flexible Circuits

CIRCUITS AND ASSEMBLY (QUALITY GUIDELINES)

IPC-A-600

Acceptability of Printed Boards

IPC-A-610

Acceptability of Printed Board Assemblies

IPC/EIA J-STD001

Requirements for Soldered Electrical & Electronic Assemblies

Visit the IPC web site at www.ipc.org

Check out the online design course: www.designingflexiblecircuits.com

It's self paced and free. The course material is divided into several chapters of solid technical information about flexible circuit materials, constructions and design layout conventions. It allows designers, or engineers an opportunity to self-educate about flexible circuits.

ALL FLEX IS AN ACTIVE, AWARD WINNING IPC MEMBER HOLDING CHAIR POSITIONS ON THE FLEXIBLE CIRCUIT MATERIALS COMMITTEE

Quotes Provided In 24 Hours

- E-mail: rfq@allflexinc.com
- www.allflexinc.com
- www.allflexheaters.com
- Secure FTP
- Call: 866-766-1334

ADDITIONAL TECHNICAL INFORMATION

TYPICAL PROPERTIES OF DIELECTRIC MATERIAL FOR FLEXIBLE PRINTED CIRCUITRY

PROPERTY (TYPICAL)	UNITS	POLYIMIDE	POLYIMIDE (Adhesiveless)	POLYESTER
REPRESENTATIVE TRADE NAME		KAPTON	KAPTON	MYLAR
PHYSICAL				
Thickness Range	mil	0.5 to 5	1-6	2-5
Tensile Strength (@25° C)	psi	25,000	50,000	20,000 to 35,000
Break Elongation	%	70	50	60 to 165
Tensile Modulus (@25° C)	100,000 psi	4.3	.7	5
Tear Initiation Strength	lb/in	1000	700-1200	1000 to 1500
Tear Propagation Strength	g/mil	0.0184	0.0088	0.0085
CHEMICAL				
Resistance to:				
Strong Acids		Good	Good	Good
Strong Alkalis		Poor	Good	Poor
Grease and Oil		Good	Good	Good
Organic Solvents		Good	Good	Good
Water		Good	Good	Good
Sunlight		Good	Good	Fair
Fungus		Non-nutrient	Non-nutrient	Non-nutrient
Water Absorption (ASTM D570)	% (24 hours)	2.9	0.8	<0.8
THERMAL				
Service Temperature (min/max)	degree C	-125/+200	-125/+200	-60/+105
Coefficient of Thermal Expansion (@22° C)	PPM/degree C	20	20	27
Change in Linear Dimensions (100° C, 30 min)	%	<0.3	0.04-0.02	<0.5
ELECTRICAL				
DIELECTRIC CONSTANT (ASTM D150) 1MHz		3.4	3.4	3
DISSIPATION FACTOR (ASTM D150) 1MHz		0.01	0.003	0.018
DIELECTRIC STRENGTH (ASTM D149) @ 1 mil thickness	V/mil	6000	6000	3400
Volume Resistivity (ASTM D257)	ohm-cm	1.0E+16	1.0E+16	1.0E+16

CURRENT CARRYING CAPABILITIES FOR EXTERNAL TRACES IN AIR

COPPER WEIGHT								
AMPS	1/2 OZ. (.0007")	1 OZ. (.0014")	2 OZ. (.0028")	3 OZ. (.0042")	4 OZ. (.0056")	5 OZ. (.007")	6 OZ. (.0084")	8 OZ. (.0112)
CONDUCTOR WIDTH IN INCHES								
0.5	.013"	.008"	N/A	N/A	N/A	N/A	N/A	N/A
1.0	.028"	.017"	.013"	N/A	N/A	N/A	N/A	N/A
1.5	.040"	.027"	.020"	N/A	.012"	.005"	.003"	N/A
2.0	.053"	.040"	.030"	.0235"	.020"	.018"	.016"	.013"
2.5	.080"	.060"	.042"	.0325"	.0285"	.024"	.023"	.018"
3.0	.100"	.083"	.057"	.045"	.0387"	.035"	.030"	.024"
4.0	.160"	.120"	.088"	.066"	.055"	.048"	.043"	.037"
5.0	.225"	.158"	.118"	.09"	.074"	.065"	.059"	.048"
6.0	.285" (off chart)	.195"	.153"	.117"	.094"	.082"	.074"	.062"
7.0	N/A (off chart)	.250"	.187"	.145"	.124"	.105"	.0905"	.075"
8.0	N/A (off chart)	.307"	.232"	.180"	.1485"	.130"	.122"	.095"

This chart gives recommendations for width of conductor needed to carry current on different copper thicknesses. For informational purposes only.

Additional helpful link: <http://circuitcalculator.com/wordpress/2006/01/31/pcb-trace-width-calculator/>

CURRENT RATING NOMOGRAPH:

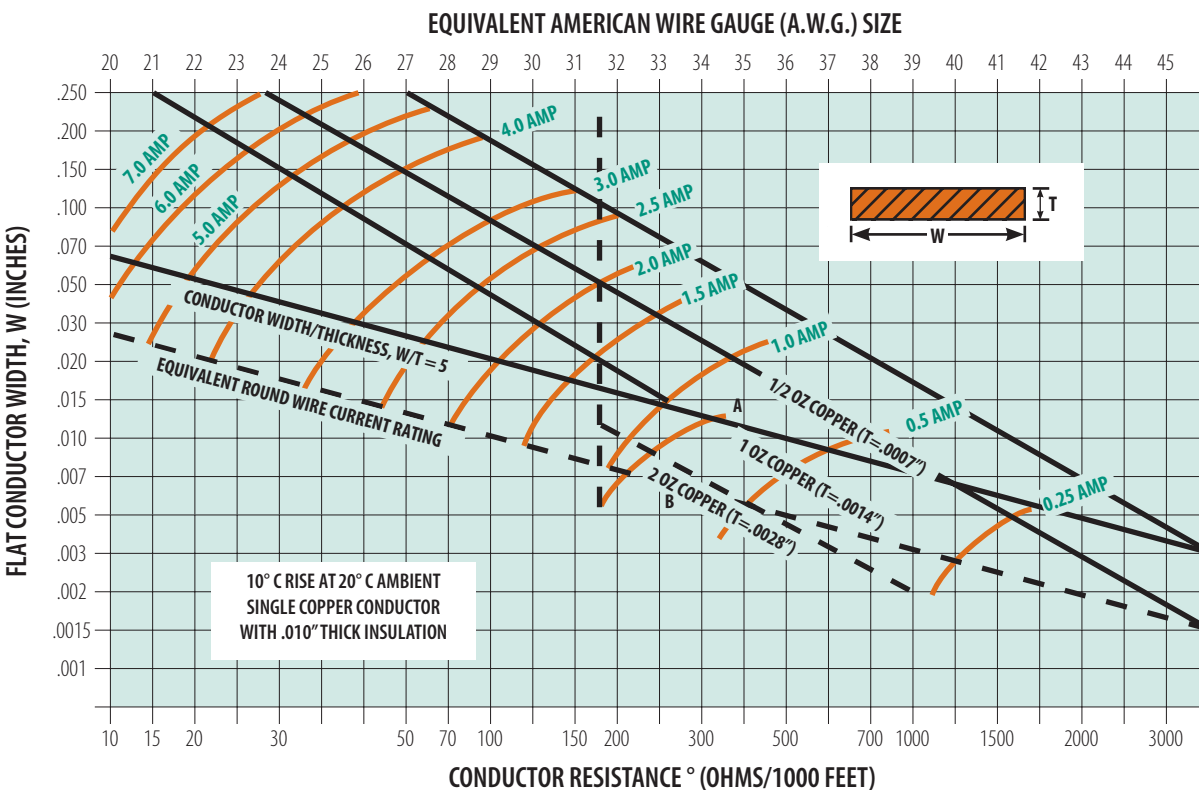

Relation between current rating and size of a single conductor for constant temperature rise in air. Conductor dimensions above the line "WIDTH/THICKNESS = 5" are preferred for ease of manufacture.

COMPUTER AIDED DESIGN (CAD) INFORMATION

DATA FORMATS:

RS 274X (Gerber)

PDF

dwg

IGES

DXF

TO COMMUNICATE:

BY E-MAIL:

General Mailbox:
information@allflexinc.com

Call ALL FLEX:

engineering toll free at
877-663-7162

README FILE SHOULD:

- Contain your company name
- Contain a list of included files and their functions
- Contain your company contact and phone number

INFORMATION CAN BE RECEIVED IN A NUMBER OF WAYS:

- Mechanical print/sketches
- Schematic drawings
- Component Specifications
- Existing Artwork to be Scanned
- Fax (507) 663-1070
- E-mail (information@allflexinc.com)
- Secure FTP: ftp://mail.allflexinc.com (contact us for password)
- Request a quote: rfq@allflexinc.com

DESIGN: ALL FLEX OFFERS THE FOLLOWING DESIGN OPTIONS FOR OUR CUSTOMERS.

- Reverse engineering of existing parts, design from concept, or design from schematic.
- Gerber creation: Contact ALL FLEX sales for more information.
- Critique of customers design for flexibility and manufacturability.

GLOSSARY

Annular Ring

That portion of conductive material completely surrounding a hole.

Art work

An accurately-scaled configuration that is used to produce the “Artwork Master” or “Production Master.”

Back -Bared Land

A land in flexible printed wiring that has a portion of the side normally bonded to the base dielectric material exposed by a clearance hole.

Base Film

The film that is the base material for the flexible printed wiring board and on the surface of which the conductive pattern can be formed. When the heat resistance is required, polyimide film is mostly used, and polyester film is usually used when the heat resistance is not required.

Blanking

Cutting a sheet of material into pieces to the specified outline.

Bondstrength

The force perpendicular to a board’s surface required to separate two adjacent layers of the board, expressed as force per unit area.

Characteristic Impedance

The resistance of a parallel conductor structure to the flow of alternating current (AC), usually applied to high speed circuits, and normally consisting of a constant value over a wide range of frequencies.

Circuitry Layer

A layer of printed board containing conductors, including ground and voltage planes.

Clearance Hole

A hole in a conductive pattern that is larger than and coaxial with a hole in the base material of a printed board.

Conductive Foil

A sheet of metal that is used to form a conductive pattern on a base material.

Connector

A device used to provide mechanical connect/disconnect service for electrical terminations.

Copper Weight

The mass of copper per unit area for a foil, typically expressed in ounces per square foot or grams per square centimeters (these units are not equivalent).

Covercoat

Material deposited as a liquid onto the circuitry that subsequently becomes a permanent dielectric coating.

Coverlay

The layer of insulating film and adhesive that is applied totally or partially over a conductive pattern on the outer surfaces of a printed board.

Crosshatching

The breaking up of large conductive areas by the use of a pattern of voids in the conductive material.

Delamination

A separation between plies within a base material, between a base material and a conductive foil, or any other planar separation within a printed board.

Dielectric

A material with a high resistance to the flow of direct current, and which is capable of being polarized by an electrical field.

Dry Film Resist

A composite material where a photosensitive emulsion that is sensitive to portions of the light spectrum and is either carried by or sandwiched between polymer release films and is used to expose imagery on printed boards.

Enig

Electroless Nickel Immersion Gold used as surface treatment for soldering and electrical contact.

Etching

The chemical, or chemical and electrolytic, removal of unwanted portions of conductive or resistive material.

Exposure

The process of generating a pattern within a photosensitive material through a chemical reaction using either laser direct imaging or conventional imaging with a working phototool.

Fiducial

A printed board feature (or features) that is (are) created in the same process as the conductive pattern and that provides a common measurable point for component mounting with respect to a land pattern or land patterns.

Flexize

Modification of an artwork to optimize manufacturability and reliability of the conductor trace pattern.

Quotes Provided In 24 Hours

- **E-mail:** rfq@allflexinc.com
- **www.allflexinc.com**
- **www.allflexheaters.com**
- **Secure FTP**
- **Call: 866-766-1334**

GLOSSARY

Flexible Heater

Custom designed polyimide and silicone rubber heaters fabricated with a variety of resistive alloys for custom heating solutions.

FR4

Epoxy based hardboard material used to make stiffeners.

Gerber Data

Most common PCB electronic data format. Consists of aperture selection and operation commands and dimensions in X- and Y-coordinates.

Land

A portion of a conductive pattern usually used for the connection and/or attachment of components.

Laser Direct Imaging (LDI)

The selective exposure of patterns onto a photosensitive material (such as dry film or liquid) without using a working phototool (artwork master).

Minimum Annular Ring

The minimum ring of metal(s) at the narrowest point between the edge of a hole and the outer edge of a circumscribing land. (This determination is made to the drilled hole on internal layers of multilayer printed boards and to the edge of the plating on external layers of multilayer and double-sided printed board).

Moisture

Absorption The amount of water the base material will absorb.

Pads Only Plating

A process with copper plated only in thru holes and on pads. Used to reduce thickness and increase flexibility and with controlled impedance requirements. Also referred to as button plating.

Panel Plating

The plating of an entire surface of a panel including holes.

Pattern Plating

The selective plating of a conductive pattern and associated holes.

Photoimaged Soldermask

Produced by a photo controlled process and used for tight pad spaces. This process enables unique openings to be applied anywhere on the circuit.

Photoresist

A photo-chemically reactive material, which polymerizes upon exposure to ultraviolet energy at a given wavelength customarily used to define an etching, plating, or selective stripping pattern on a substrate.

Polyimide

The synthetic polymer that has more than two imide radicals in the main chain. DuPont trademark is Kapton®.

PSA

Pressure Sensitive Adhesive.

Resistive Metal

Copper alloy or other metals selected for their resistive properties to design flexible heaters.

Rolled Annealed

Copper rolled foil to a predetermined thickness and then treated through an annealing process.

Shielding, Electronic

A physical barrier, usually electrically conductive, that reduces the interaction of electric or magnetic fields upon devices, circuits or portions of circuits.

Silkscreen

A process for applying nomenclature legend.

Stiffener Board

A material fastened to the surface of a printed board to increase its mechanical strength.

Via

A plated-through hole that is used as an interlayer connection, but in which there is no intention to insert a component lead or other reinforcing material.

Source for most terms: "Terms and Definitions for Interconnecting and Packaging Electronic Circuits" IPC-T-50

See www.ALLFLEXINC.com/EngineeringTools/Glossary for a complete listing of flexible circuitry terms.

REQUEST FOR QUOTE (RFQ) GUIDELINE

FLEXIBLE CIRCUITS Part Number: _____

*Approximate Part Dimensions: _____ Inches _____ MM

Number of conductive layers: _____

Smallest Diameter hole: _____

Approximate Overall Thickness: _____

*Quantity to Quote: _____

Surface Finish: HASL Tin ENIG Elec. Gold OSP
 Immersion Nickel Immersion Silver Unsure

Does the part require assembly?

- Yes, but All Flex will not handle the assembly
- Yes, include assembly pricing (please provide All Flex BOM)
- No
- Undetermined

HEATER Part Number: _____

*Approximate Part Dimensions: _____ Inches _____ MM

*Quantity to Quote: _____

*Material Construction: Polyimide OR Silicone Rubber

*Voltage _____

*Power (Watts) _____

Temperature range required: _____

Approximate Overall Thickness: _____

Wires/if any: (length/gauge/insulation): _____

Does the heater require assembly?

- Yes, but All Flex will not handle the assembly
- Yes, include assembly pricing (please provide All Flex BOM)
- No
- Undetermined

You can also request online
www.allflexinc.com

Email To: information@allflexinc.com

or Fax To: 507-663-1070

Attention: Sales Applications Engineers

Your Name: _____

Email: _____

Phone: _____

Company: _____

Address: _____

All Flex Design Considerations

Please provide All Flex with Heater CAD data, pdf or sketch if available.

Quotes Provided In 24 Hours

- E-mail: rfq@allflexinc.com
- www.allflexinc.com
- www.allflexheaters.com
- Secure FTP
- Call: 866-766-1334

AS9100 Certified

ISO 9001 Certified

ITAR Registered

MIL-PRF-31032/3 Qualified

MIL-PRF-31032/4 Qualified

RoHS Compliant

UL Recognized

IPC Member

JCP Certified



All Flex Solutions

1601 Cannon Lane
Northfield, MN 55057

(507) 663-7162

www.AllFlexInc.com

